

Z CHEMGEAR™

D SERIES DRY FLOCCULANT MIX AND FEED SYSTEMS

Zeroday's dry flocculant mixing and feeding equipment designs are fully automated robust systems that will provide years of trouble free service, producing consistently excellent flocculant solutions. These are designed and fabricated focused on "Providing our customers peace of mind so they can focus on things that really matter." Built with operators and applications in mind based on many years of hands on flocculation mixing and flocculant-thickener operation experience, Zeroday endeavors to supply systems that maximize process performance and minimize operator attention by building high quality systems with an attention to ease of use and effectiveness details.

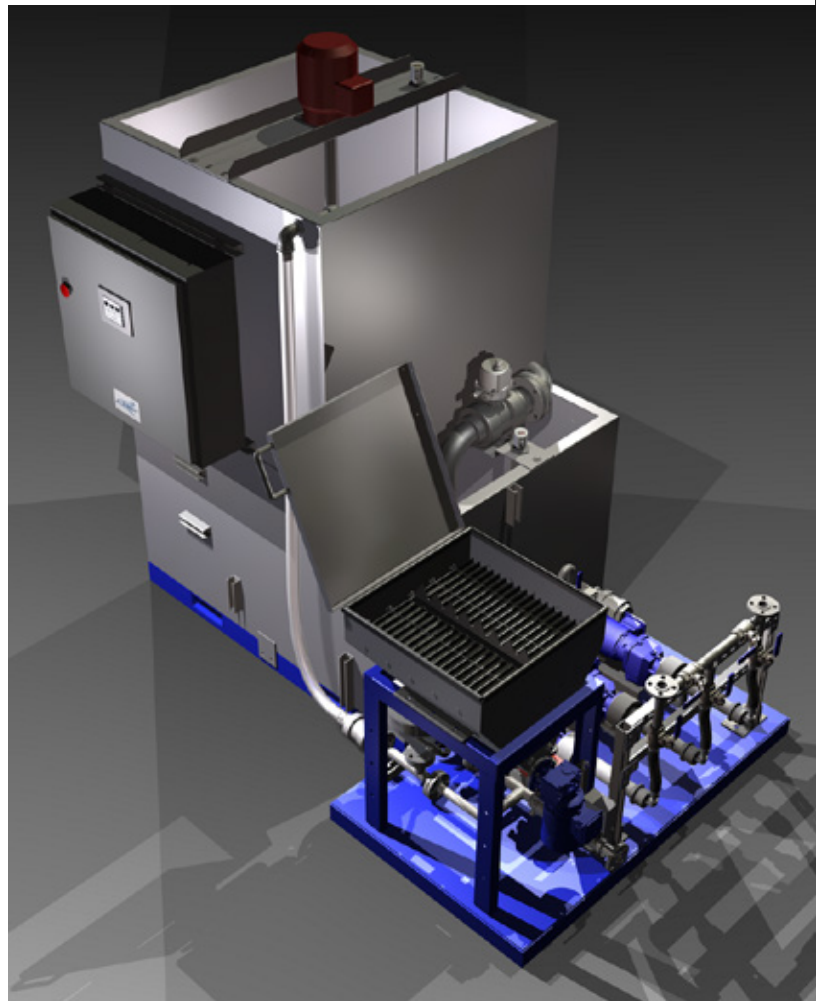

Z CHEMGEAR™ | D SERIES DRY FLOCCULANT MIX AND FEED SYSTEMS

ChemGear™ D Series 50-1500 units are fully skid mounted “plug and play” systems requiring minimum installation time and effort: set in place, plumb water and flocculant feed lines and connect power.

Design, material & fabrication quality strictly controlled with documented industry standards (ANSI, AWS, OSHA, MSHA). Our systems factory commissioned prior to shipping, thoroughly tested with initial customer specific settings which are adjusted on setup to customer site conditions.

Larger capacity systems requiring separated tanks are built with the same high design and fabrication standards as the Z ChemGear 50-1500 systems. These are also factory commissioned to minimize installation and startup effort.

Standard system features include:

- » Fully skid mounted, over-under mix and day tank configuration
- » HMI-PLC controls
- » All weather hopper with variable speed auger
- » Stainless steel materials used for tanks, mixer, hopper-auger, and wetting chamber
- » Powder coated steel skid construction
- » Stainless steel butt-welded pump manifold. Flexible final connections for ease of maintenance
- » Skid with 3 variable speed, progressive cavity, feed pumps with panel mounted VFDs
- » Mixing tank with turbine mixer
- » Large storage tank with excess capacity
- » Wash-down ready electrical components & wiring (NEMA 4)

While Zeroday will customize the systems to meet customer requirements and preferences, the following are typical options:

- » Number of operating-standby flocculant feed pumps and pump skid configuration
- » Flocculant solution rate measurement: drawdown tubes, flowmeters
- » Manual system controls
- » Range of international power options available
- » Small sack (55 lb/25 kg) and bulk bag (1200 lb/544 kg and higher) options
- » Bulk bag hopper or flocculant pan options
- » Bag and pallet hoists
- » English and native languages for manuals and HMI
- » Customization with customer preferred brand components
- » Wireless/remote equipment monitoring
- » DCS/SCADA communication

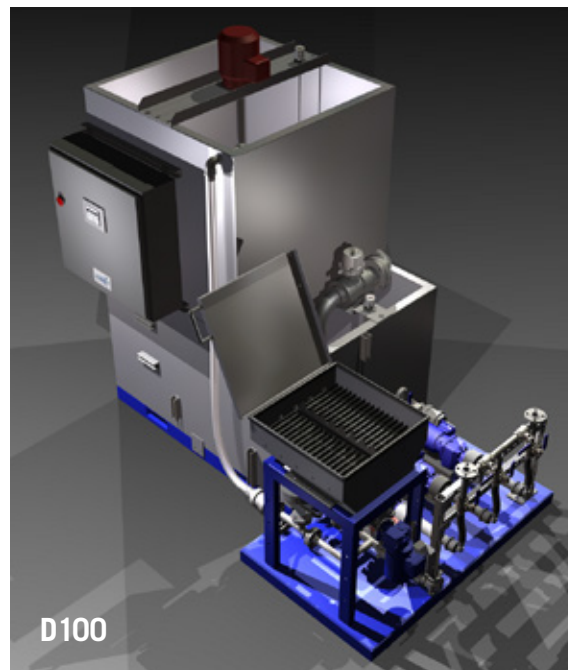

D100

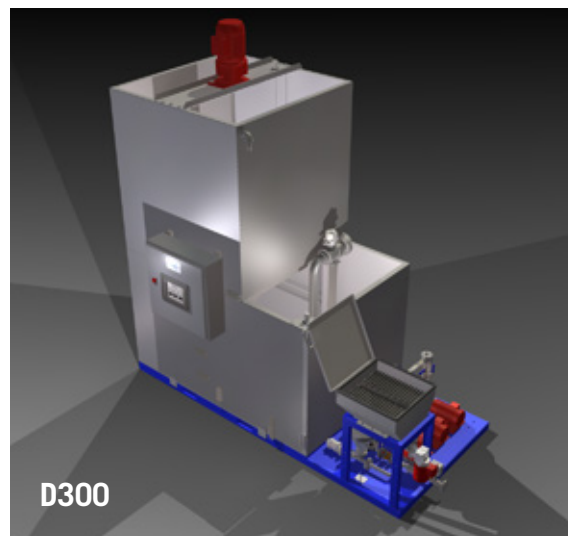

D300

The following standard systems are available. Larger capacity systems are available but more customized to application requirements.

SYSTEM CAPACITY*

MODEL	HOURLY		DAY, 24 HR OPERATION	
	Llb/hr	Kg/hr	Lb/day	Kg/day
D50	2.1	1.0	50	22.7
D100	4.2	1.9	100	45.4
D300	12.5	5.7	300	136
D750	31.2	14.2	750	340
D1500	62.5	28.3	1500	680

*Based on 0.25% flocculant solutions, 1 hour mixing time requirement